

ALM Technology(HongKong) Ltd

8E, Haiyuege, Huijinghaoyuan, Science and Industry Park,
Nanshan District, Shenzhen, Guangdong, 518057, China.
TEL: +86-755-86366560 FAX: +86-755-26583393
Email: Jack.Liu@almtechnology.com Mob: 15013832081

Module Specification**Of****ALM-803****BC05-MM-External**

Product Name	Module Specification Of ALM-803 (BC05-MM-External)
Customer	TBD
Revision	R1.1

Product Development Department		DATE
Prepared By	Winson	2008-4-24

External)

Approved By	Winson	2008-11-18
--------------------	---------------	-------------------

DOCUMENT CHANGE HISTORY

Version	Date	Person	Remarks
R1.0	2008-4-24	Kevin	First release
R1.1	2008-11-11	winson	Format changed

CONFIDENTIAL
www.almtechnology.com



Directory

1. Introduction.....	3
2. Specification.....	3
2.1 Features.....	3
2.2 Module Feature and Interface.....	4
2.3 Module Dimension.....	4
2.4 Pin Configuration.....	5
2.5 Product Specification.....	6
2.6 Electrical Characteristics.....	6
2.7 RF Characteristics.....	7
3. Interface Part.....	7
3.1 PIO Interface.....	7
3.2 Audio Interface.....	7
4. Typical Application Circuit Drawing.....	8
5. Function Tests Drawing.....	9

1. Introduction

1.1 Product Introduction

The ALM-803 is a high performance Bluetooth module for embedded AV Bluetooth applications. Integrated with Flash, Crystal, Radio, Link control, Codec, DSP, Flash and MCU, This all-in-one module provides the potential to cost down client's BOM cost. The only external components needed are antenna, Microphone, Speaker and components for power supply and UI circuitry.

ALM-803 is also designed for low power applications including sleep and deep sleep modes, and operates from a single 1.8V or 3.3V supply. It supports AV/Headset/Handsfree/TTS/OPP profile. With compliance to Bluetooth V2.0 standard, the ALM-803 provides a fully compliant Bluetooth system for data and voice communications. The integrated Stereo CODEC and an open platform digital signal process or (DSP) co-process or allows for support of enhanced audio applications in more compact designs. Further more, ALM-803 is able to provide faster connection, Adaptive Frequency Hopping (AFH) and extended SCO link, The latter two features help on improving voice quality. ALM-803 offers great flexibility by configurable PIO pins. With free choice of suitable definitions of PIO pins, Customers can easily fit ALM-803 into their product design and greatly shorten time-to-market.

ALM-803 is a single-chip radio and baseband IC for Bluetooth 2.4GHz systems. When used with the CSR Bluetooth stack, it provides a fully compliant Bluetooth V2.1+ EDR specification system for data and voice.

1.2 Applications

1.2.1 High-quality Stereo Headset

1.2.2 Hands-free Car Kits

1.2.3A/V USB Dongle

1.2.4 GPS BT

1.2.5 Wireless Speakers

1.2.6 VoIP Handsets

1.2.7. Automotive Wireless Gateways

2. Specification

2.1 Features

- Communication Standard: Bluetooth Spec. V2.0 /V2.1 Compliant
- Support Mode: A2DP-SINK, AVRCP,Headset, Hands Free

External)

- Operating Frequency Band: 2.402GHz to 2.483GHz unlicensed ISMBand
- OutputPower: -6 dBm to 4dBm(Class 2)
- Link Mode: SCO, ACL
- Audio Codec: Integrated 16-bit linear Aduio Codec,S/N Ratio>90dB
- Low Power Mode Support: Park, Sniff, Hold and Deep Sleep
- Built-in 16-bit stereo codec.
- May drive speaker by 150mW, and do not need connect audio amplifier
- Integrative 64MIPS Kalimba DSP Co-processor
- It's high integration and periphery circuit is easy

Module feature and Interface

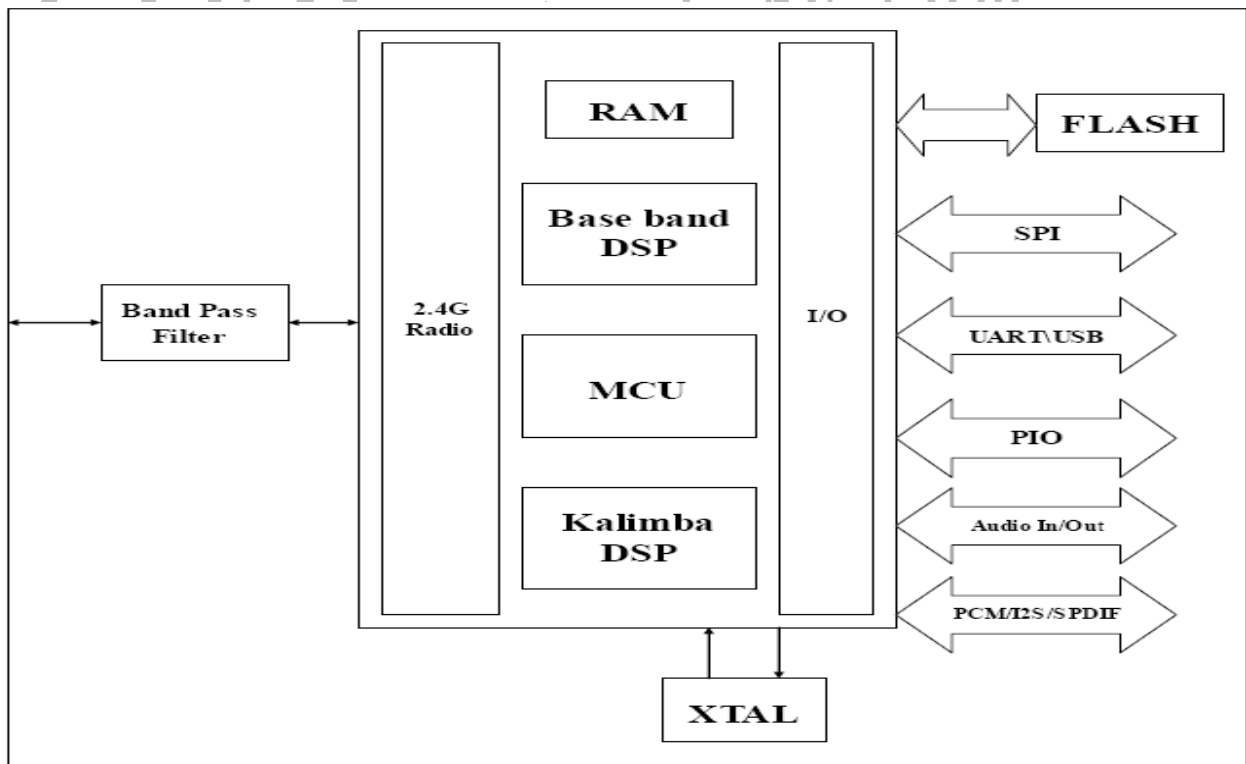

External)

2.3 Module Dimension

Unit: mm

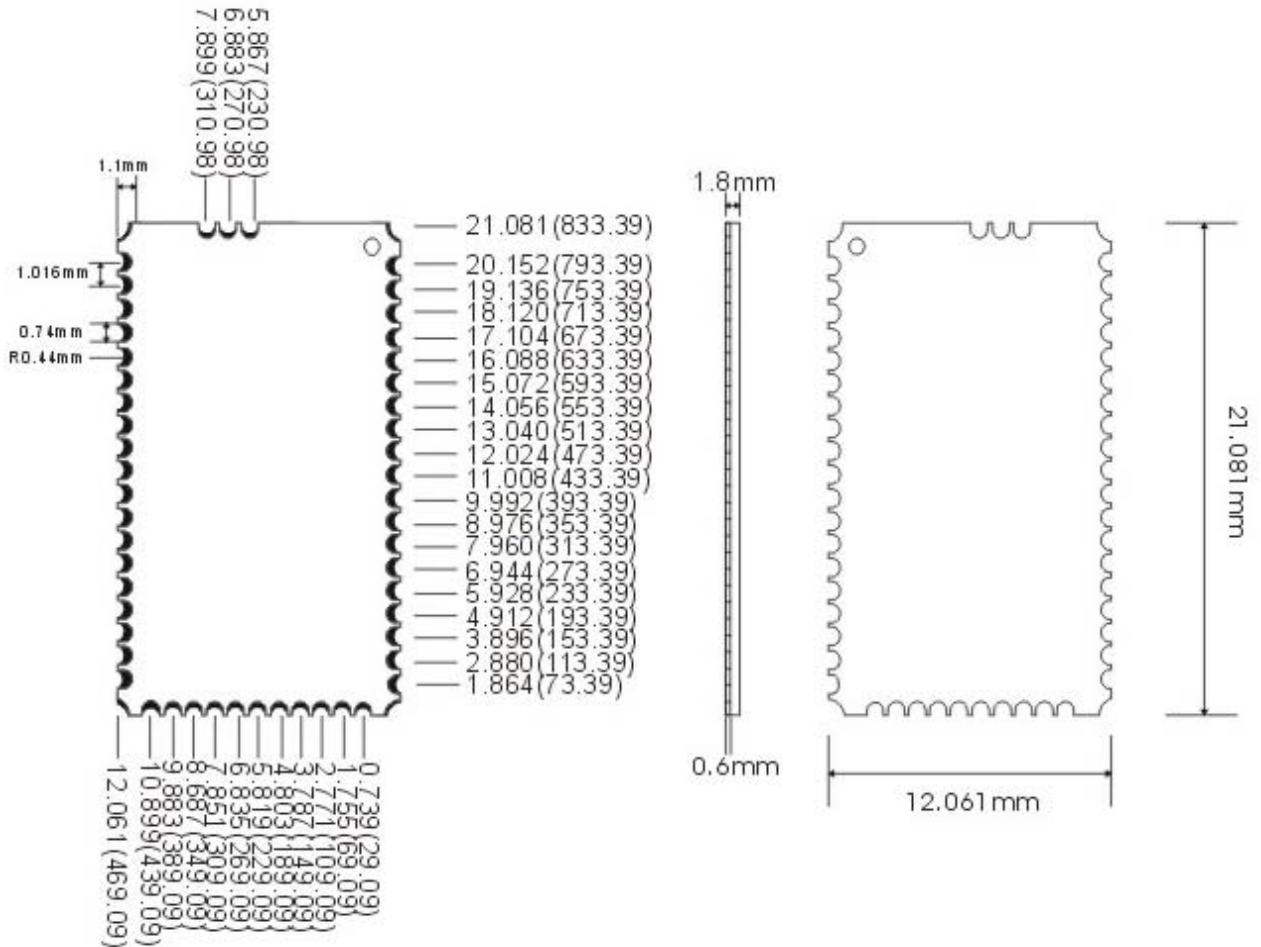

NO PIN NAME	NO PIN NAME	NO PIN NAME	NO PIN NAME
1 GND	14 UART_RTS	27 GND	40 SPK_R_N
2 PIO2	15 UART_CTS	28 VREGENABLE-H	41 SPK_R_P
3 PIO3	16 UART_TX	29 VDD_BAT	42 MIC_BIAS
4 PIO8	17 GND	30 VDD 1.8V	43 MIC_R_P
5 PIO10	18 PIO9	31 SPI_CSB	44 MIC_R_N
6 GND	19 PIO11	32 SPI_MISO	45 MIC_L_N
7 AIO1	20 USB_DN	33 SPI_MOSI	46 MIC_L_P
8 AIO0	21 USB_DP	34 SPI_CLK	47 GND
9 GND	22 PIO6	35 LED1	48 PIO1
10 VDD 1.8V	23 PIO5	36 LED0	49 PIO0
11 VCC 3.3V	24 PIO4	37 VDD_CHG	50 GND
12 GND	25 PIO7	38 SPK_L_N	51 RF
13 UART_RX	26 RESET	39 SPK_L_P	52 GND

2.4 PIN Configuration

External)

PIN NO.	NAME	DIR	TYPE	FUNCTION	REMARK
1	GND	-	GND	Ground	
2	PIO[2]	I/O	BI-DIRECTIONAL	Programmable Input / Output	
3	PIO[3]	I/O	BI-DIRECTIONAL	Programmable Input / Output	
4	PIO[8]	I/O	BI-DIRECTIONAL	Programmable Input / Output	
5	PIO[10]	I/O	BI-DIRECTIONAL	Programmable Input / Output	
6	GND	-	GND	Ground	
7	AIO[1]	I/O	BI-DIRECTIONAL	Programmable Input / Output	
8	AIO[0]	I/O	BI-DIRECTIONAL	Programmable Input / Output	
9	GND	-	GND	Ground	
10	VDD	O	POWER	+1.8V Supply Output	
11	VCC	O	POWER	+3.3V Supply Output	
12	GND	-	GND	Ground	
13	UART_RX	I	INPUT	UART Data In	
14	UART_RTS	O	OUTPUT	UART Request To Send (Active Low)	
15	UART_CTS	I	INPUT	UART Clear To Send (Active Low)	
16	UART_TX	O	OUTPUT	UART Data Out	
17	GND	-	GND	Ground	
18	PIO[9]	I/O	BI-DIRECTIONAL	Programmable Input / Output	
19	PIO[11]	I/O	BI-DIRECTIONAL	Programmable Input / Output	
20	USB_DN	I/O	BI-DIRECTIONAL	USB Data Minus	
21	USB_DP	I/O	BI-DIRECTIONAL	USB Data Plus	
22	PIO[6]	I/O	BI-DIRECTIONAL	Programmable Input / Output	
23	PIO[5]	I/O	BI-DIRECTIONAL	Programmable Input / Output	
24	PIO[4]	I/O	BI-DIRECTIONAL	Programmable Input / Output	
25	PIO[7]	I/O	BI-DIRECTIONAL	Programmable Input / Output	
26	RESETB	I	INPUT	Reset (Active Low)	
27	GND	-	GND	Ground	
28	VREG_H	I	POWER	Regulator Control Pin	
29	VDD	O	POWER	+1.8V Supply Output	
30	VBAT	I	POWER	Battery Positive Terminal	
31	SPI_CS	I	INPUT	Chip Select For Synchronous Serial Interface (Active Low)	
32	SPI_MISO	O	OUTPUT	Serial Peripheral Interface Data Output	
33	SPI_MOSI	I	INPUT	Serial Peripheral Interface Data Input	
34	SPI_CLK	I	INPUT	Serial Peripheral Interface Clock	
35	LED[1]	O	OUTPUT(Open Drain)	Current Sink to Drive LED	
36	LED[0]	O	OUTPUT(Open Drain)	Current Sink to Drive LED	
37	VDD_CHG		input	Lithium ion/polymer battery charger input	
38	SPK_L_N	O	ANALOGUE	Speaker Out Negative , Left	
39	SPK_L_P	O	ANALOGUE	Speaker Out Positive , Left	
40	SPK_R_N	O	ANALOGUE	Speaker Out Negative , Right	
41	SPK_R_P	O	ANALOGUE	Speaker Out Positive , Right	
42	MIC_BIAS	I	ANALOGUE	Microphone bias	
43	MIC_R_P	I	ANALOGUE	Microphone Positive Input , Right	
44	MIC_R_N	I	ANALOGUE	Microphone Negative Input , Right	
45	MIC_L_N	I	ANALOGUE	Microphone Negative Input , Left	
46	MIC_L_P	I	ANALOGUE	Microphone Positive Input , Left	
47	GND	-	GND	Ground	
48	PIO[1]	I/O	BI-DIRECTIONAL	Programmable Input / Output	
49	PIO[0]	I/O	BI-DIRECTIONAL	Programmable Input / Output	
50	GND	-	GND	Ground	
51	RF	I/O	Analogue	Antenna	
52	GND	-	GND	Ground	

External)

2.5 Product Specification

Items	Specification
Operating Frequency Band	2.402GHz to 2.483GHz unlicensed ISMBand
Bluetooth Specification	V2.0
Output Power Class	Class2
Operating Voltage	3.3V
Host interface	USB1.1 or UART
Low Power Mode Support	Park, Sniff, Hold and Deep Sleep
Audio interface	PCM,Speaker, Microphone, I2S, SPDIF

2.6 Electrical Characteristics

Absolute Maximum Rating	Min	Max
Storage Temperature	-40°C	+85°C
3.3V Version		
Supply Voltage Vcc	3.0V	3.7V
Supply Voltage:VREN_IN	3.0V	4.2V
Supply Voltage:BAT_P	3.0V	4.2V
Supply Voltage:V_CHG	4.3V	6.5V

Recommended Operating Conditions	Min	Max
Operating Temperature Range	-25°C	+75°C
3.3V Version		
Supply Voltage Vcc	3.0V	3.7V
Power Consumption	Units	Average
Page Scan	mW	1
Peak Current mA	45	Peak
ACL data over 115k Baud UART at mW Maximum throughput(Master)	29	Peak
ACL data over 115k Baud UART at mW Maximum throughput(Slave)	45	
ACL data over USB at maximum thro mW Ughput (Master)	134	
ACL data over USB at maximum mW Throughput (Slave)	69	
SCO correction HV1, Master mW	78	
SCO correction HV1, Slave mW	79	
SCO correction HV3, Master mW	45	
SCO correction HV3, Slave mW	54	
Connection, No data traffic master mW	17	
Connection, No data traffic master mW	39	

2.7 RF Characteristics

Transmitter	Units	Min	Type	Max	Bluetooth Spec
Output Power	dBm	-	2.0	-	-6 to 4
Power Control Range	dB	-	2.74	-	2<P<8
20dB Bandwidth	kHz	-	716.1	-	<1000
2 nd Adjacent Channel Power(+/- 2MHz)	dB	-	-47.57	-	<-30
3 rd Adjacent Channel Power(+/- 3MHz)	dB	-	-58.63	-	<-40
Modulation Characteristic	kHz	-	Df1max=163 Df1avg=171.3 Df2max=173.0 Df2avg=162.6 Df2avg/Df1avg=0.949		140<Df1max<175 Df2max>115 $\Delta f2avg/\Delta f1avg \geq 0.8$
ICFT	kHz	-	-7.3		ICF<75
Carrier Frequency Drift	kHz	-	DH1 -1.4 DH3/DH5 -2.3		For DH1<25 For DH3/DH5<40K

External)

VDD=3.3V, Operating Temperature: 25°C, Operating Frequency Band:2.402 GHz to 2.483GHz.

Transmitter	Units	Min	Typ	Max	Bluetooth Spec
Single-slot Sensitivity at 0.1% BER	dBm	-	-81	-	-70
Single-slot Sensitivity at 0.1% BER	dBm	-	-80	-	-70
Maximum Receiver Signal	dBm	-	-20	-	-20
C/I CO-Channel	dB	-	9	-	11

VDD: 3.3V, Operating Temperature: 25°C, Operating Frequency Band: 2.402 GHz to 2.483GHz.

3. Interface Part

3.1PIO Interface

PIO0-PIO11 can be used to control, display,data bus,etc.

3.2Audio Interface

SPKR and SPKL are used for external speaker. It uses a fully differential output.

Signal to Noise ratio:90dB

Frequency Respond:20Hz-20KHz.

Output Level: Typical 0.7V RMS, Max 1V RMS

The audio input circuitry consists of a dual audio input that can be configured to be either single ended or fully differential

Input Level: Max 1V RMS

4. Function Test Drawing

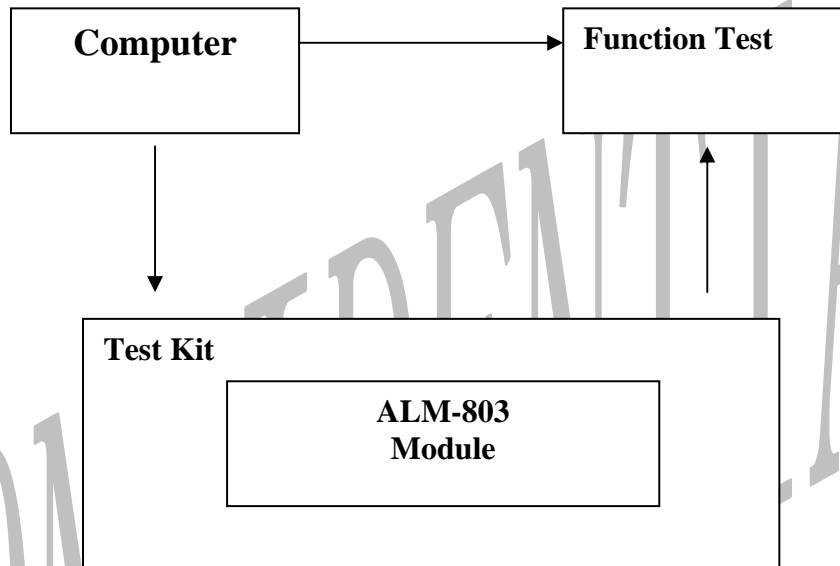

The End